

Model 3200 Stainless Steel Series Universal

Why INTERFACE 3200 series load cells are the best in class:

- Hermetically sealed cell
- Environmentally sealed cable
- Accuracy to .05%
- Compact size
- High 4mV/V output
- Eccentric load compensated*
- .0008%/°F temp effect on output*
- Low deflection
- Shunt calibration
- Barometric compensation
- Tension and compression

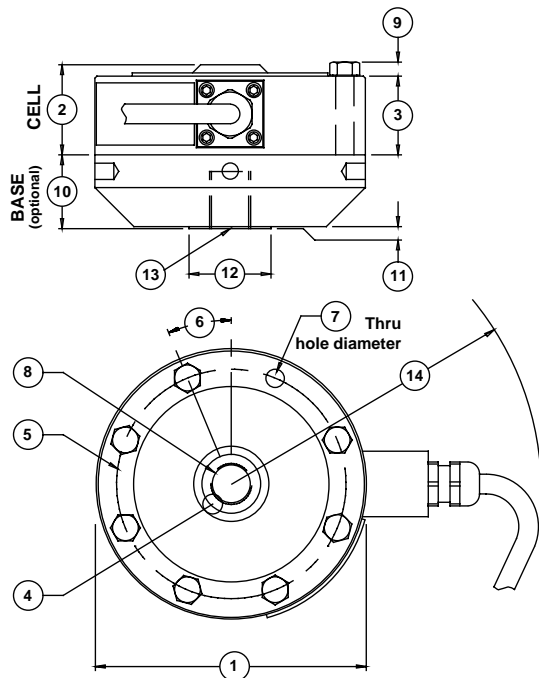

DIMENSIONS

See Drawing	3210		MODEL 3220		3232	
	CAPACITY (lbf)					
	5K, 10K		25K		100K	
	inch	mm	inch	mm	inch	mm
①	4.13	104.8	6.06	153.9	8.00	203.2
②	1.38	34.9	1.75	44.5	2.50	63.5
③	1.20	30.5	1.58	40.0	2.20	55.9
④	0.90	22.9	1.97	50.0	3.14	79.8
⑤	3.50	88.9	5.13	130.3	6.50	165.1
⑥	22.5°	22.5°	15.0°	15.0°	11.25°	11.25°
⑦	0.28	7.10	0.41	10.4	0.53	1.50
⑧	5/8-18 UNF-3B		1 1/4-12 UNF-3B		1 3/4-12 UNF-3B	
⑧	1.12 in deep		1.73 in deep		2.15 in deep	
⑨	0.20	5.10	0.30	7.60	0.31	7.90
⑩	1.13	28.6	1.75	44.5	2.00	50.8
⑪	0.03	0.80	0.03	0.80	0.03	0.80
⑫	1.25	31.8	2.25	57.2	3.00	76.2
⑬	5/8-18 UNF-3B		1 1/4-12 UNF-3		1 3/4-12 UNF-3	
⑬	0.87 in deep		1.73 in deep		2.15 in deep	
⑭	4.80	121.9	5.52	140.2	5.30	134.6

Model 3200 Stainless Steel Series Universal

SPECIFICATIONS

PARAMETERS	3210	3210	MODEL		
	5K	10K	3220	3220	3232
	CAPACITY (lbf)				
	5K	10K	25K	50K	100K
ACCURACY – (MAX ERROR)					
Static Error Band-% FS	± 0.05	± 0.05	± 0.05	± 0.05	± 0.06
Nonlinearity-% FS	± 0.05	± 0.05	± 0.05	± 0.05	± 0.05
Hysteresis-% FS	± 0.06	± 0.06	± 0.06	± 0.06	± 0.06
Nonrepeatability-% RO	± 0.01	± 0.01	± 0.01	± 0.01	± 0.01
Creep, 20 min.-%	± 0.025	± 0.025	± 0.025	± 0.025	± 0.025
Side Load Sensitivity-%	± 0.25	± 0.25	± 0.25	± 0.25	± 0.25
Eccentric Load Sensitivity-%/in	± 0.25	± 0.25	± 0.25	± 0.25	± 0.25
TEMPERATURE					
Compensated Range-°F	15 to 115	15 to 115	15 to 115	15 to 115	15 to 115
Compensated Range-°C	-10 to 45	-10 to 45	-10 to 45	-10 to 45	-10 to 45
Operating Range-°F	-65 to 200	-65 to 200	-65 to 200	-65 to 200	-65 to 200
Operating Range-°C	-55 to 90	-55 to 90	-55 to 90	-55 to 90	-55 to 90
Effect on Zero-%RO/F – MAX	± 0.0008	± 0.0008	± 0.0008	± 0.0008	± 0.0008
Effect on Output-%/F – MAX	± 0.0008	± 0.0008	± 0.0008	± 0.0008	± 0.0008
ELECTRICAL					
Rated Output-mV/V (Nominal)	4.00	4.00	4.00	4.00	4.00
Nominal Excitation Voltage-VDC	10	10	10	10	10
Bridge Resistance-Ohm (Nominal)	350	350	350	350	350
Zero Balance-% RO	± 1.0	± 1.0	± 1.0	± 1.0	± 1.0
Insulation Resistance-Megohm	5000	5000	5000	5000	5000
MECHANICAL					
Safe Overload-% CAP	± 150	± 150	± 150	± 150	± 150
Deflection @ RO-inch	0.002	0.002	0.002	0.002	0.003
Optional Base-P/N	B302	B302	B303	B303	B312
Natural Frequency-kHz	6.6	9.4	6.5	7.0	5.8
Weight-lb	3.3	3.3	9.5	9.5	26
Calibration	T & C	T & C	T & C	T & C	T & C

OPTIONS*

Base (recommended)
 Compression overload protection
 Cable length (20 ft. standard)
 Multiple bridge
 Standardized output

ACCESSORIES*

Instrumentation
 Loading hardware
 Load button
 Top & bottom plates



Optional base

* Please call for additional information